

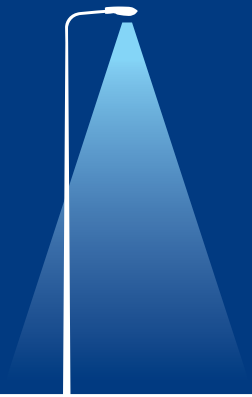

Aluminium Lighting Company



clearly better

LIGHTING COLUMNS

BESPOKE COLUMNS

SIGNALS AND SIGNPOSTS

from any angle



in partnership with



www.aluminium-lighting.com

passively safe

robust

low maintenance

long life

sustainable

ALC

Clearly better from any angle

At the Aluminium Lighting Company (ALC), we believe our success comes from dedication to our core values. We pride ourselves on our teamwork-focused customer service, our operational excellence and the innovative nature of our products and services.

As the first company to introduce extruded aluminium lighting columns into the UK and the leading supplier of these products in the country, we are uniquely positioned to advise lighting engineers, architects, local authorities and developers.

Our intelligently engineered aluminium outperforms other column types in terms of passive safety and ongoing maintenance costs, and doesn't even require painting. We provide a wide standard range along with more aesthetic bespoke options and offer whole-life cost savings and wide-ranging regulatory compliance.

Knowledge & expertise

Our market understanding, long-standing product knowledge and ongoing process innovation has positioned us as the market's leading supplier of aluminium columns; saving local authorities and developers money up and down the country, and saving vehicle occupants' lives on the roads.

Each product undergoes robust structural performance calculations before manufacture, and our designs offer peace of mind for specifiers who have statutory safety obligations.



Barry Williams (far right) and son Craig head up South Wales-based Aluminium Lighting Company.

“Our combination of unique market position and truly added-value product offering means we can concentrate on servicing our clients to the highest standard.”



In brief

- **First in the UK** – ALC has unbeatable experience in the industry, and years of product development behind it
- **Market knowledge** – UK experience meets European expertise, with backing from aluminium giant Nedal
- **Technical excellence** – ALC's manufacture is unmatched, with weld-free reinforcement, industry-leading structural bonding and stringent strength calculations
- **Delivered for you** – optimised delivery, high stock levels and quick quote turnarounds make ordering easy.





Market needs

ALC understands what our customers want, and we understand how the lighting column market will look in the coming years. Aluminium is clearly the future of lighting columns, being easier to install, involving minimal maintenance/testing and lasting for years longer than the alternatives, and we are the company best placed in the UK to advise and deliver.

We keep large stocks of columns on site, as do our partner distributors, for quick turnarounds on orders of all sizes, our quoting process is equally speedy, and many of our customers tell us we're a pleasure to deal with. Even more bespoke products can also be turned around quickly, and we offer optimised delivery to reduce costs to our customers.



Designed for Britain



Understanding the UK market is what we do best. ALC has designed and set up specifications with numerous local authorities and offers this service to all, making the procurement process as hassle-free as possible.



We are partnered with major supplier Nedal in the Netherlands, one of Europe's leading aluminium extruders, meaning we can supply our customers quickly, and in volume.



Accreditations

ALC is passionate about quality, staff training and the environment, reflected in the following accreditations:



Working towards:
Investors in People

Working towards:
ISO 14001



Aluminium

Best by far...

The benefits are impossible to ignore: more durable, safer, requiring no maintenance – these attributes of extruded aluminium lighting columns are reason alone to consider it as the only choice when planning a lighting scheme, but they're not the only reasons...

Best value



The cost of a lighting project is about far more than the price of materials. Engineers realise they must consider installation, painting and maintenance when making their value calculations, and it's here that aluminium really outshines the competition.



Requiring no maintenance, aluminium is corrosion-resistant and has a lifespan which vastly exceeds the nearest competing product – it's designed for a 50 year life and our products regularly exceed this. In addition, it is usually supplied unpainted, meaning it keeps its natural gleaming finish for its lifetime without any need to repaint. Its enhanced structural integrity means no testing is required, saving you significantly in the long term and offering you return on investment in just a few years.

The safer solution



Passive safety is key to aluminium's appeal as a column material. The material absorbs kinetic energy and is less likely to cause harm in a vehicle collision and for many of

ALC's products passive safety crash testing certification is available upon request (tested to BS EN 12767:2007). Our press-stressed inner sleeve reinforcement technology is weld-free and guarantees column strength. Any welding that is undertaken is done to the highest technical standard by coded welders, and we undertake rigorous weld calculations.

Saving money now and in the future

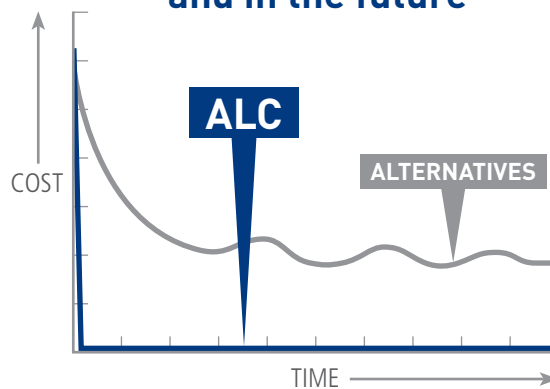

“The benefits of the material can be summed up in a few words: passive safety and whole-life cost savings.”

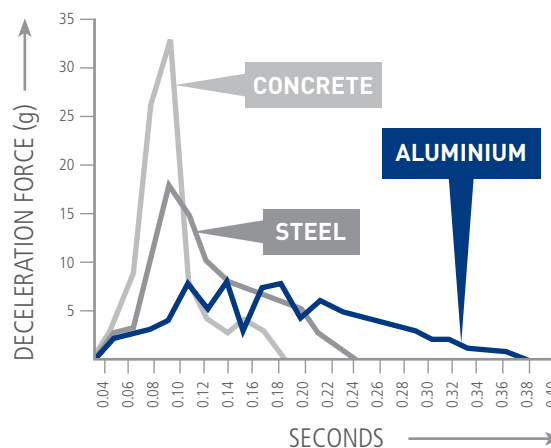



Best value in focus

Lightweight and easy to install

Despite their strength, some of our smaller columns are so light that they require no mechanical lifting device to install. Installation times are speeded up and projects can meet tight deadlines more easily.

Ultra-low maintenance

As aluminium is resistant to corrosion and – being naturally attractive – it doesn't require painting/re-painting, there is very little call for maintenance and whole-life cost savings result.



Trouble-free long life

With no corrosion and loss of structural integrity over decades, our customers save money on replacing and repairing columns. Our columns require no structural surveying during their 50 year design life.

Environmentally friendly

Our columns are manufactured from 100% recycled aluminium. The aluminium we use is itself 100% recyclable when the column reaches the end of its working life, and aluminium has a lower carbon footprint than many competing products. Our columns have no need for sacrificial coatings, and due to their lightness, our optimised transport scheduling and the ability to fit more columns in per delivery, less energy is used in getting them to customers.



Tried and tested

Aluminium has been the material of choice for lighting columns in Europe and the USA for years, its many advantages being adopted by public and private bodies in numerous countries.



Range

Lighting columns

Most of our customers come to us for our market-leading off-the-shelf lighting columns, which we are able to prepare and dispatch within a matter of days, including a less than 24 hour turnaround on quotations.

Our standard range has been designed to fit our customers' needs, and is available from 3m-18m in our market-leading conical shape (as well as stepped or cylindrical options). With cable entry guards, dual-locking doors, thermoplastic root protection and type 5 press-stressed reinforcing sleeves as standard, the range is suitable for any scheme. Additional options include various brackets, finishes and protective additions – further information is available at www.aluminium-lighting.com or in our Lighting Column brochure.

Bespoke columns

Architecturally-led housing estates, regeneration schemes, town centre redevelopments – ALC has a proud history of creating aesthetically-pleasing lighting columns and street furniture for a wide range of unique uses. Our in-house design team is highly-talented and customer focused, able to work from architect's sketches to full CAD drawings and 3D models.

Our services including finishing in any RAL colour where required, special metal cutting for bespoke designs and even unique column types and sizes where required. We also have a range of conceptual products which we have designed for those customers looking for something different, and our products are on the cutting edge of modern technology.

Traffic signal poles and signposts

Similar principals of manufacture and material can be applied to our range of standard traffic signal poles and signpost columns as those we use to create our industry-leading lighting columns. They can be stepped or cylindrical, and our traffic signal poles are capped and drilled to take electrics.

Check out our interactive column selector at www.aluminium-lighting.com

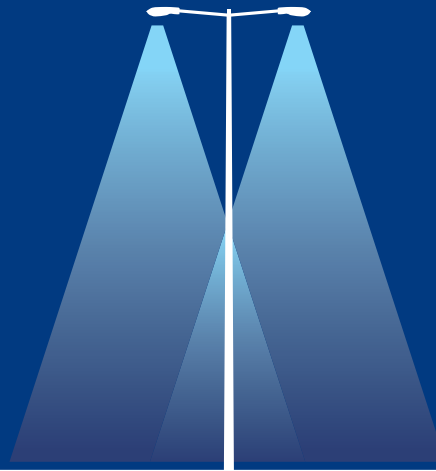

Lighting columns

Please see our Lighting Column brochure for more information or visit our website

Columns available from 3m-18m

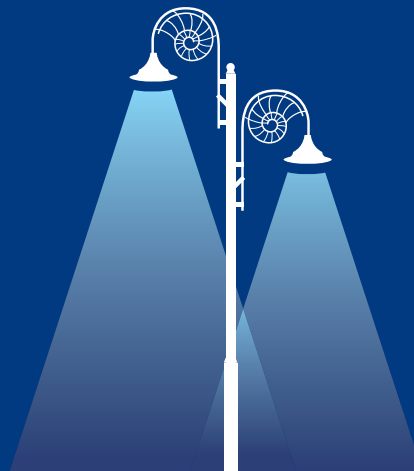

Bespoke columns

Please see our Lighting Columns brochure for more information or visit our website

Columns available from 3m-18m

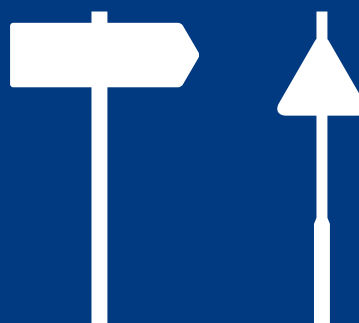

Traffic signal poles and signposts

Please visit our website for more information



Simple specification



By selecting from an always-stocked range of column types and heights, you can be guaranteed that the product meets your exact needs and our high standards without having to spend time and money on design specifications. We can even create and store a set of specifications unique to your organisation, making ordering even smoother and easier in the future.

We carry out structural calculations on each and every column we deliver to ensure that it is fit for purpose. We are also able to optimise delivery to save customers money.



“We have created a Product Selector document to make choosing the right column even easier for our customers.”

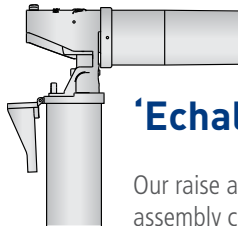

'Echalon' hinge

Our raise and lower hinge assembly can be applied to any of our columns (from 4m to 6m).

Excellence

Customer first

By adopting a positive teamwork approach with our customers - as well as internally - we ensure open, regular communication with our clients. This ethos exists throughout the company.

Innovations

It was ALC that originally brought extruded aluminium columns to the UK, but the innovation haven't stopped there. We are constantly coming up with new ways to exceed customer requirements, be it more environmentally-friendly manufacturing processes, lighter reinforcements, structural bonding, high-quality coded welding (with rigorous weld calculations), structural integrity calculations, cutting-edge conceptual designs and even potential IT integration.

Uniquely, our columns use type 5 press-stressed aluminium reinforcing tube inserts – a weld-free process that dramatically increases strength.

If you have a forward-looking lighting idea you'd like to see become a reality, speak to us.

Memberships

ALC's quality and reliability has been recognised by a number of industry bodies:



“It's a simple formula: we employ the best people we can to supply the best product on the market.”

In brief

- **Reputation** – our relationship-based customer service has won us repeat business time and time again
- **Cost savings** – we realise the importance of the bottom line, and our offering equals whole-life ROI that cannot be surpassed in the marketplace
- **Design** – our expert team is creative, skilled and experienced in real-world application
- **Best in the business** – we're determined to hire talented people who really understand our company values





People

Our team is made up of experienced and dedicated professionals; people who understand the whole of our market (lighting engineers, H&S officers, architects, developers, highways engineers etc) so they can be sure of meeting multiple stakeholder requirements, just like our products do.

Processes

Our innovations are not limited to our products: we aim to innovate at every step, from our customer service to our internal processes, to our delivery and distribution.

Each of our processes is outward-looking, so you can be assured of end-to-end support from the moment you first pick up the phone until long after your lighting scheme is completed, with our technical expertise always at your disposal.

Training

Like any forward-looking business, we maintain up-to-date training schedules for all our staff, so when you speak to one of our designers or our customer service team, you can be assured they understand exactly your requirements and concerns. We operate apprentice programmes and our coded welders are trained to the highest level.

Development

Our products, our service, our staff – we're always developing our business in line with our customers' needs. No matter how well we do, we strive to do better, and this means keeping in touch with our customers to find out what they're looking for now, and in the future.

Future

Designed for today

Our strong position in the market exists because we make a product that meets the needs of numerous customers and stakeholders right now: our columns are strong and designed to meet or exceed passive safety standards, so our customers are assured that their lighting schemes will do no harm; the attractive material and the numerous designs we offer mean that more architecturally-driven schemes can be successful without excessive costs; and the technical knowledge of our staff and the simple specification processes we offer make life easier for busy lighting and highways engineers.

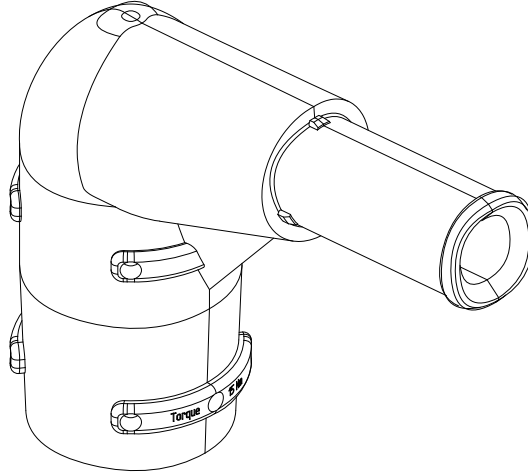

Development for tomorrow

Sustainability in construction or engineering might seem like a relatively new concept to some, but we've been producing a product for years which is more environmentally friendly than any of the alternatives, and it's clear that aluminium is the column choice for a sustainable future.

As lighting and building regulations develop, so will our designs; ALC will always be on the cutting edge of technology and innovation.

“ALC was formed as a company for now and for the future, and we're never going to stop innovating.”



In brief

- **Sustainability** – no lighting column product can match ours in terms of sustainability of material, manufacture, delivery and life-span
- **Stakeholders** – we've listened not only to our customers, but to those who influence them too, ensure we satisfy numerous stakeholder needs
- **Innovation** – we drive ahead in terms of our revolutionary products as much as our ever-improving customer service
- **Corporate Social Responsibility** – we take our responsibilities seriously, and seek to position ourselves as an important part of our community





The environment

We share our customers' dedication to the environment. Our production processes are clean and low-energy, the lighter weight of aluminium means less CO₂ emissions from transport, and its durability means less CO₂ emissions from maintenance/replacement works. Aluminium is a lower embodied-CO₂ metal than competing materials; so it's clear that aluminium columns (made from recycled metal and themselves completely recyclable) are the sustainable future for the market.

Carbon neutral columns are available, please get in touch for more information.

Responsibilities

We take our responsibilities to our industry and our community very seriously. We regularly support our staff's charity projects, as well as directly funding local charities and schools. We employ from within the local community and offer work placements for the unemployed; ten percent of our workforce has been employed via apprentice schemes. In addition we are striving to attain the Investors in People Gold standard, and offer support for the ILE's 'Young Lighting Professionals' scheme.



We also have a duty toward our clients, ensuring that we help them to meet their own commitments; we understand that customers may have legal obligations with regard to column passive safety, and can guarantee our products fully comply with design and verification strength requirements by calculation under BS EN 40-3-3:2003.



**Call our customer service team on
01639 852502**

**For more information please visit
www.aluminium-lighting.com**

Aluminium Lighting Company Limited

Croeserw Industrial Estate, Eastern Avenue
Cymmer, Port Talbot SA13 3PB

T: 01639 852502

F: 01639 852263

E: sales@alulight.co.uk

W: www.aluminium-lighting.com

Distribution partners:



MARWOOD
LIGHTING
DISTRIBUTORS



Best Value

ALC offers the best return on investment in the market, with tangible and significant long-term cost savings.

Robust

Our industry-leading manufacturing process guarantees strength built-in, and aluminium won't corrode so structural integrity is maintained long-term.

Long Life

An aluminium column from ALC has a design life of 50 years (with a track record in the ground exceeding this) – far outlasting steel or concrete.

Low Maintenance

No need to paint and no need to survey for structural integrity; we even offer a hinged column for easy lantern access.

Passively Safe

Aluminium absorbs kinetic energy better than competing materials, so our columns are less likely to kill or cause harm during a road traffic accident.

Sustainable

Our aluminium is 100% recycled and 100% recyclable, and has a lower carbon footprint than alternative column materials.

Easy Selection

The ALC website features an interactive product selector for quick enquiries, and once we're aware of your requirements we can agree long-term specifications to make your purchasing even easier in the future. Please visit: www.aluminium-lighting.com



Printed upon 100% recycled paper using environmentally friendly processes
Designed and produced by Horizon Digital Media Ltd www.horizondml.co.uk

Clearly better from any angle brochure - August 2010/01